

## Street Port Exhaust System Installation

### Important Note:

This exhaust system is intended for use on engines with “street porting”. It is assumed that an aftermarket intake system is being used. Read the following instructions thoroughly before starting.

### Installation

1. Remove all stock exhaust system components from the chassis.

#### 1985 model only:

The small temperature probe originally installed behind the catalytic converter is unnecessary and should be removed.

2. Position the Racing Beat header and center section of the Racing Beat exhaust system along side the chassis, as they will be installed. Assemble the header and center section using the gasket, bolts, lock washers and nuts supplied with the header hardware kit. Do not fully tighten the assembly at this time.

**Center Section Installation:** the following instructions are for specific model years.

#### 1979-1980 models only:

Install the supplied L-bracket with the shorter end attached to the center section at the position shown in Figure 1. Use the 20mm long bolt and 8mm split washer to secure the bracket in the orientation shown.

#### 1981-1983 models only:

Attach the supplied long straight strap on the center section at the position indicated in Figure 1. Later, after placing the exhaust system on the car, the other end of this strap will attach to the hanger flange located on the transmission.

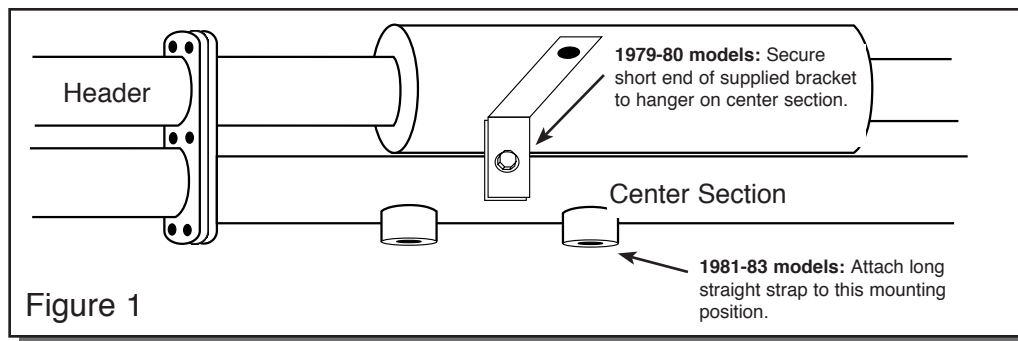

5. Install the header and center section assembly on the chassis using the new engine-to-header gasket and original nuts and washers. Do not fully tighten the assembly at this time. Secure the front mount on the center section using the original bolt (except 1984-85 models). See Figure 2 for locations.

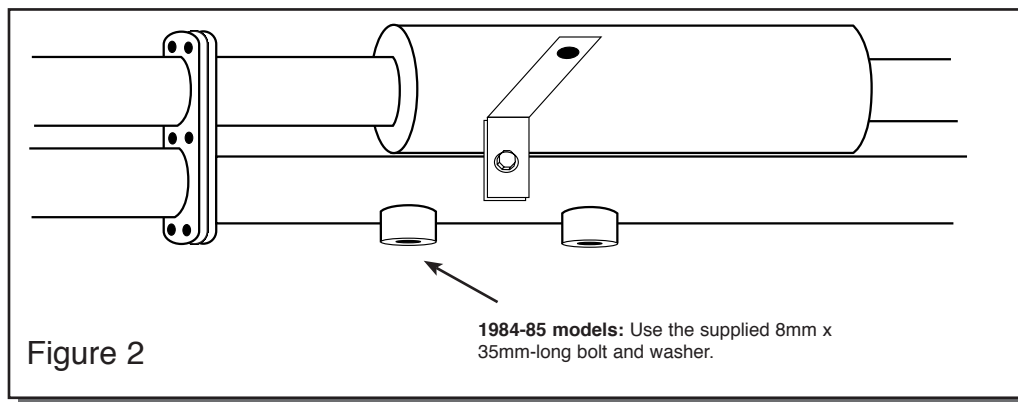

**1984-1985 models only:**

Use the supplied 35mm-long bolt and split washer. Do not fully tighten at this time.

7. Attach the rear mount on the center section using the original bolt. Do not fully tighten the assembly at this time.

Depending on your model, not all hardware will be used.

8. Observe any locations on the exhaust system which have less than 1/2-inch clearance. Modify or remove heat shields that do not clear. Gradually tighten all joints starting at the engine and position the exhaust to take maximum advantage of the bolt clearance, maintaining a constant 1/2-inch clearance. In some cases, it may be necessary to loosen the engine mounts and rotate the the engine slightly to obtain the required clearance.

9. Install the muffler using the supplied gasket, 3/8" nuts & lock washers, and the original hangar hardware.

10. Installation is now complete. Check for any signs of exhaust gas leakage. Operating a motor vehicle with an exhaust gas leak is extremely dangerous. If you suspect a leak and are not able to determine the source, seek the aid of a qualified mechanic.